

Foam Storage Tanks

Tank Accessories | Bladder Tank Manual Filling Pump



Features

Locking ring on shaft

Note. Must be ordered with bladder tank

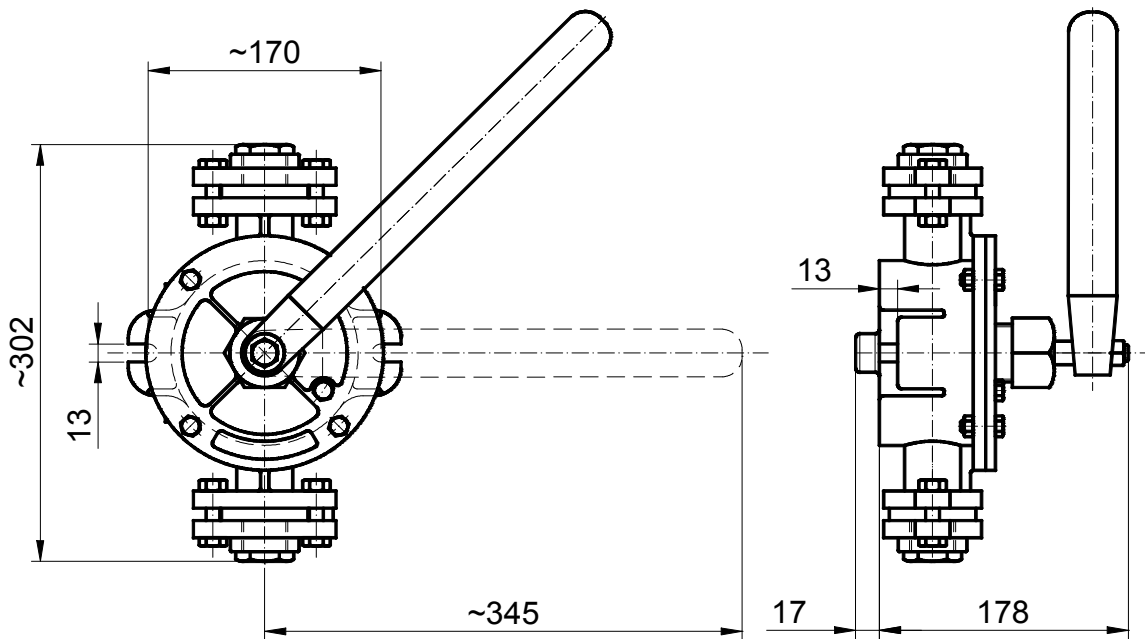

Part number	Pipes		Litres / Cycle	Litres / 1"	Weight (kg)
	(inch)	(mm)			
PUMPKITEX2	1	25	0.665	50	7.2

SP2.3.1.8/0417/en

Note: This document contains basic product information only. Information, photos and drawings are not contractually binding. In all cases, the manufacturer's full technical documentation remains the reference document. The contents of this publication are subject to modifications without notice. All rights reserved.

